



Diesel Forklift 2/2.5/3/3.5T CPCD20/CPCD25/CPCD30/CPCD35



ISUZU C240 ENGINE (1)



Mitsubishi S4S Engine



China engine C490



Forklift with Cabin

Model			CPC(D)20	CPC(D)25	CPC(D)30	CPC (D) 30H	CPC(D)35	CPC(D)38	CPC(D)40 S	CPC(D)40 Big	
Specifications	Drive type		Diesel	Diesel	Diesel	Diesel	Diesel	Diesel	Diesel	Diesel	
	Rated loading	kg	2000	2500	3000	3300	3500	3800	4000	4000	
	Load center	mm	500	500	500	500	500	500	500	500	
	Lifting height	mm	3000	3000	3000	3000	3000	3000	3000	3000	
	Free lift height	mm	0	0	100	100	100	100	100	100	
	For size	L*W*H	mm	1070×122×40	1070×122×40	1070×125×45	1070×125×45	1070×125×50	1070×125×50	1070×125×50	1070×125×50
	Mast Tilt	Fwd/Bwd	Deg	6/12	6/12	6/12	6/12	6/12	6/12	6/12	6/12
	Min.Turning radius		mm	2190	2240	2400	2470	2470	2470	2470	2470
		Mast	mm	120	120	135	135	135	135	135	135
	Min.ground clearance	Frame	mm	130	130	140	140	140	140	140	140
			mm	2160	2160	2165	2165	2165	2165	2165	2165
	Guard height		mm	2160	2160	2165	2165	2165	2165	2165	2165
Front overhang		mm	450	450	490	490	490	490	490	490	
Performance	Max.Travel speed	Loaden	km/h	19	19	20	20	20	20	20	
	Max.Lift speed	Loaden	mm/s	500	500	480	480	480	480	480	
	Max.traction force	Loaden	KW	17	18	20	22	22	22	22	
	Gradeability		%	20	20	20	20	20	20	20	
Dimension	Overall length	with fork	mm	3600	3650	3770	3870	3870	3970	3970	
		no fork	mm	2530	2580	2700	2800	2800	2900	2900	
	Overall width		mm	1160	1160	1225	1225	1225	1225	1225	
	Mast Extend height(with backrest)		mm	4220	4220	4265	4265	4265	4265	4265	
Mast lowered height		mm	2100	2100	2100	2100	2100	2100	2100		
Chasis	Tire	Front		7.00-12	7.00-12	28x9-15	28x9-15	28x9-15	28x9-15	300-15	
		Rear		6.00-9	6.00-9	6.50-10	6.50-10	6.50-10	6.50-10	7.0-12	
	Wheelbase		mm	1600	1600	1700	1800	1800	1900	1900	
	Difference	Front wheels/Rear wheels	mm	970/970	970/970	1000/970	1000/970	1000/970	1000/970	1000/970	
Self weight		Kg	3530	3880	4350	4300	4605	4900	5020		
Driving	Battery	V/Ah	12/80	12/80	12/80	12/80	12/80	12/80	12/80	12/80	
	Engine	Model		Quan Chai/Xin Chai	Quan Chai/Xin Chai	Quan Chai/Xin Chai	Quan Chai/Xin Chai	Quan Chai/Xin Chai	Quanchai High Pressure Common Rail (GBIII/Beijing IV)	Quanchai High Pressure Common Rail (GBIII/Beijing IV)	MITSUBISHI S4S
		Rated power	kw/r.p.m	36.8/2500	36.8/2500	36.8/2500	36.8/2500	36.8/2500	36.8/2500	36.8/2500	35.3/2250
		Rated torque	Nm/r.p.m	156/1700-1900	156/1700-1900	156/1700-1900	156/1700-1900	156/1700-1900	180-190/1800-2000	180-190/1800-2000	166/1700
		Bore X stroke	mm	90×105	90×105	90×105	90×105	90×105	93×105	93×105	94×120
		Number of cylinders		4	4	4	4	4	4	4	4
		Displacement	L	2.54	2.54	2.54	2.54	2.54	2.85	2.85	3.33
Fuel tank capacity	L	60	60	70	70	70	70	70	70		
Gear (front/rear)		2/2 manual powershift (1/1 automatic powershift)									

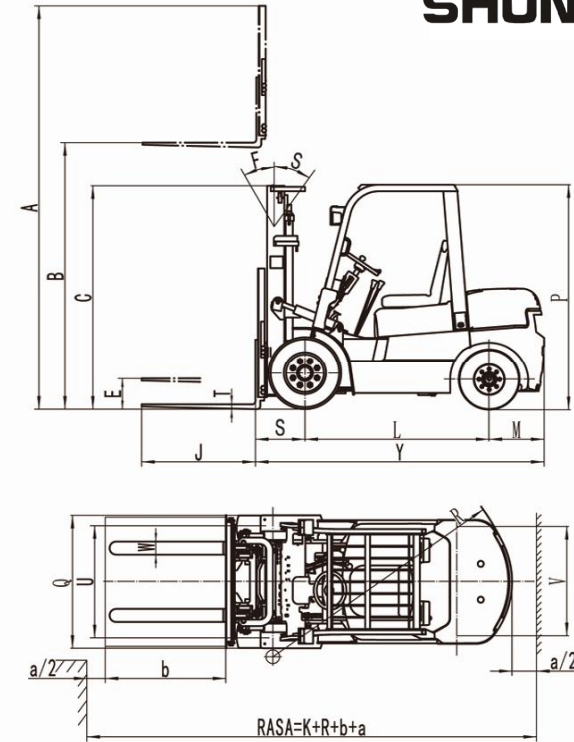
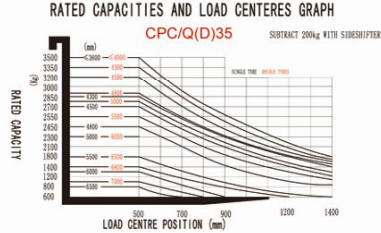
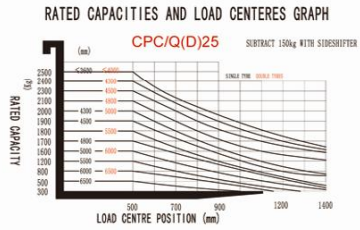
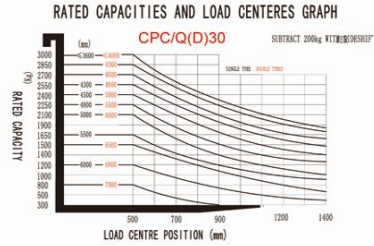
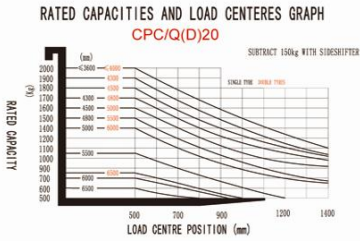

Engine Data

Model				CPC(D)
Type				Diesel
Drive	Engine	Battery	Voltage/ Capaity	V/Ah 12/80
		Model		C490BPG
		Rated Power	kw/r.p.m	36.8/2500
		Rated Torque	Nm/r.p.m	156/1700-1900
		Cylinder diameter X stroke	mm	90×105
		Number of cylinders		4
	Emissions	L	2.54	
Fuel tank capacity		L	70	

